

Cryogenic-Fill cluster, 725 P.S.I.
Stainless steel body and bronze topwork
with check function and drain valve
“live loaded” gland packing
“ cleaned and degreased for oxygen service “

Part No. 07016.X.5000
Fill connection: Mueller Flange (not shown)
Socket weld connection for stainless steel pipes
acc. to DIN EN ISO 1127 and ASTM A312

Available options - on request only:
· other fill connections

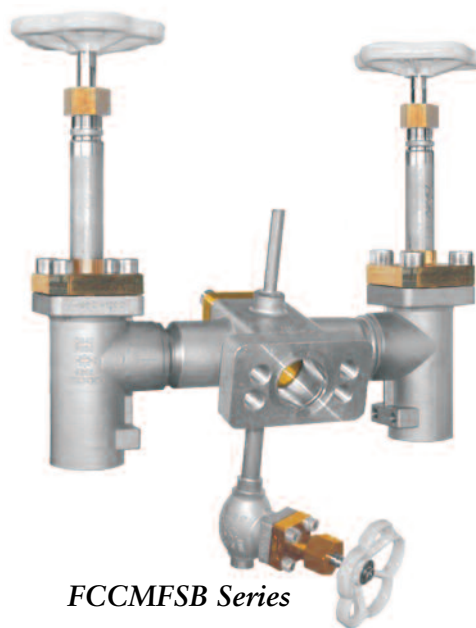

Applications:
Approved for air gases, vapours and cryogenic liquefied gases incl. LNG.
Working temperature: -196°C / -321°F (77K) up to +120°C / +248°F (393K)

Materials	ASTM
1 Fill body	A 351 CF8
2 Body	A 351 CF8
3 Valve seal	PTFE / Carbon filled (25%)
4 Disc	B 283 UNS C38500
5 Bonnet gasket	PTFE
6 Headpiece	B 505 UNS C93200
7 Bolts	A 194 B8
8 Elongation tube	A 213 TP 321
9 Stem	A 276 Grade 304
10 Gland packing	Graphite / PTFE
11 Gland nut	B 283 UNS C38500
12 Handwheel	Aluminium alloy
14 Check disc	B103 UNS C51900
15 Spring	A 276 Grade 316Ti
16 Cap	B 505 UNS C93200

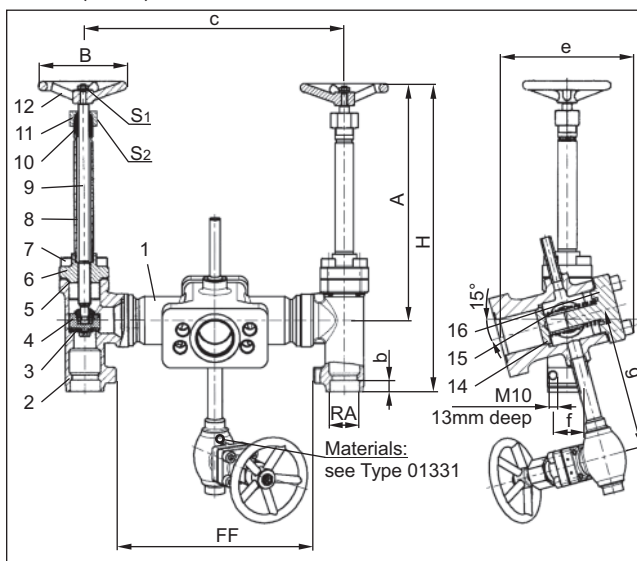

Standard marking acc. to Pressure Equipment Directive 97/23/EG (PED).



Type 07017 – Standard design	Technical data		
Nominal size	Inches	1"	1½"
Dimensions code	.X.	2533	4048
Face-to-face dimension	FF	225	225
Outside pipe-ø DIN EN ISO 1127	RA	33.7	48.3
Outside pipe-ø ASTM A312	RA	33.40	48.26
Socket depth	b	13	13
Height	A	270	270
Height	H	350	350
Length	c	295	301
Length	e	76	76
Length	f	32	32
Length	g	160	160
Handwheel-ø	B	100	125
Wrench size across flats	S ₁	10	13
Wrench size across flats	S ₂	30	36
Weight	LBS.	24.64	30.8

Dimensions in mm