

**Cryogenic-Globe and Globe/Check Valves, 725 P.S.I.**

Stainless steel body and bronze topwork,  
“live loaded” gland packing  
“cleaned and degreased for oxygen service ”

- Part No. 03321.X.0013 (H = 270mm)
  - Part No. 03321.X.0023 (H = 370mm)
  - Part No. 03321.X.5013 (H = 270mm) Globe/Check Valve
  - Part No. 03321.X.5023 (H = 370mm) Globe/Check Valve
- Flanged connection acc. to ANSI B16.5 class 300

Available options - on request only:

- Extension H up to 900mm (36")
- Valve with control disc (tapered design)



GVFLSB Series

**Applications:**

Approved for air gases, vapours and cryogenic liquefied gases incl. LNG.  
Working temperature: -196°C / -321°F (77K) up to +120°C / +248°F (393K)

Materials	ASTM
1 Body	A 351 CF8
2 Valve seal up to 2"	PTFE / Carbon filled (25%)
2a Valve seal from 2-1/2"	PTFE
3 Disc	B 283 UNS C38500
4 Bonnet gasket	PTFE
5 Headpiece	B 505 UNS C93200
6 Bolts	A 194 B8
7 Elongation tube	A 213 TP 321
8 Stem	A 276 Grade 304
9 Gland packing	Graphite / PTFE
10 Gland nut	B 283 UNS C38500
11 Handwheel	Aluminium alloy
12 Spring	B 103 UNS C51900

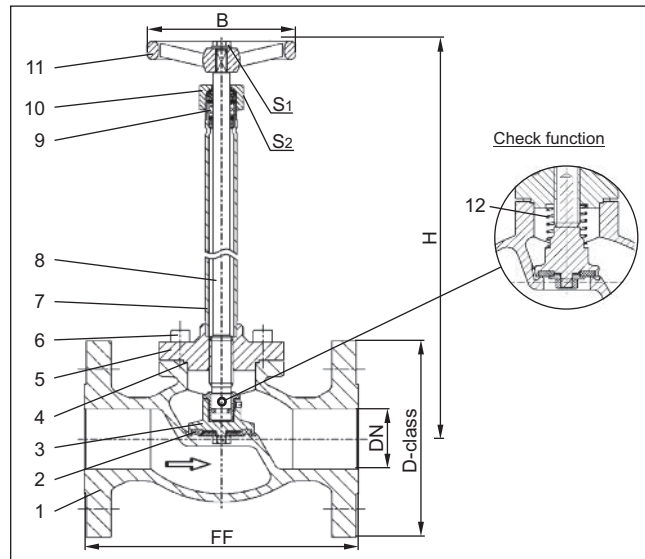

Standard marking acc. to Pressure Equipment Directive 97/23/EG (PED).



Marking acc. to Directive 99/36/EG (TPED) will only be carried out by written notice on purchase order.



Type 03321 – Standard design	Technical data						
	Inches	1"	1½"	2"	2½"	3"	4"
Nominal size	.X.	1000	1400	2000	2400	3000	4000
Dimensions code – Flange ANSI B16.5 class 300	D-class	123.9	155.4	165	190.5	209.5	254
Flange-ø	FF	160	200	230	290	310	350
Face-to-face dimension	H	270 mm or 370 mm (10½" or 14½")		400	400	400	400
Height	B	100	125	125	200	250	315
Handwheel-ø	S <sub>1</sub>	10	13	13	13	13	13
Wrench size across flats	S <sub>2</sub>	30	36	36	36	36	41
Weight	LBS.	10.78	21.34	29.26	46.42	61.6	95.04
CV-Value	gal/min	13.4	26.3	43.2	82.7	120.9	195.2

Dimensions in mm