

Cryogenic-Globe and Globe/Check Valves, 725 P.S.I. (4" = 580 P.S.I.)

- Stainless steel body and topwork,
- "live loaded" gland packing
- "cleaned and degreased for oxygen service"

Part No. 01351.X.000*

Part No. 01351.X.500* Globe/Check Valve

*Butt weld connection for stainless steel pipes acc. to DIN EN ISO 1127 or ASTM A312

Part No. 01351.X.0004

Part No. 01351.X.5004 Globe/Check Valve

Socket weld connection for stainless steel pipes acc. to DIN EN ISO 1127 and ASTM A312

Available options - on request only:

- Welded stainless steel stubs acc. to DIN EN ISO 1127 or ASTM A312 - length FF + 150mm(6")
- Valve with control disc (tapered design)



GVNSS Series

Applications:

Approved for air gases, vapours and cryogenic liquefied gases incl. LNG.

Working temperature: -196°C / -321°F (77K) up to +120°C / +248°F (393K)

Recommended working temperature: -60°C / -76°F (213K) up to +120°C / +248°F (393K)

Materials	ASTM
1 Body	A 351 CF8
2 Valve seal up to 2"	PTFE / Carbon filled (25%)
2a Valve seal from 2-1/2"	PTFE
3 Disc	A 276 Grade 304
4 Bonnet gasket	PTFE
5 Headpiece	A 276 Grade 304
6 Bolts	A 194 B8
8 Stem	A 276 Grade 304
9 Gland packing	Graphite / PTFE
10 Gland nut	A 276 Grade 303
11 Handwheel	Aluminium alloy
12 Spring	A 276 Grade 302
13 Bush	B 130 Alloy A

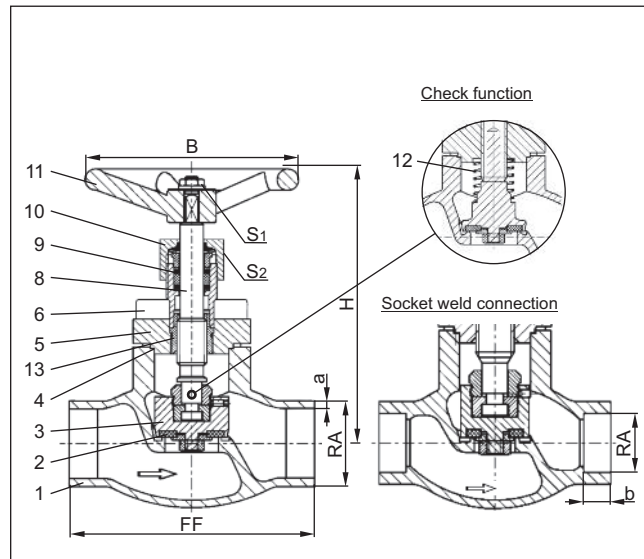

Standard marking acc. to Pressure Equipment Directive 97/23/EG (PED).



Marking acc. to Directive 99/36/EG (TPED) will only be carried out by written notice on purchase order.



Type 01351–Standard design	Technical data												
	Nominal size	Inches	3/8"	1/2"	1/2"	3/4"	1"	1 1/4"	1 1/2"	1 1/2"	2"	2 1/2"	3"
Dimensions code	.X.	1012	1517	1521	2026	2533	3238	4042	4048	5060	657x	8088	0114
Face-to-face dimension	FF	70	85	85	100	115	115	130	130	155	205	245	280
Height	H	140	140	140	140	140	170	175	175	200	260	310	350
Outside pipe -ø DIN EN ISO 1127	RA	12.0	17.2	21.3	26.9	33.7	38.0	42.4	48.3	60.3	76.1	88.9	114.3
Wall thickness pipe DIN EN ISO 1127	a	1.0	1.6	2.0	2.0	2.0	2.0	2.0	2.0	2.0	2.6	3.2	6.0
Outside pipe -ø ASTM A312	RA	13.72	17.15	21.34	26.67	33.40	-	42.16	48.26	60.33	73.03	88.90	114.3
Wall thickness pipe ASTM A312	a	S10	S40	S10	S10	S10	-	S10	S10	S10	S40	S10	S40
Socket depth	b	6	10	10	13	13	-	13	13	16	16	16	20
Handwheel-ø	B	80	100	100	100	100	125	125	125	200	250	315	
Wrench size across flats	S ₁	10	10	10	10	10	13	13	13	13	13	13	13
Wrench size across flats	S ₂	30	30	30	30	30	36	36	36	36	36	36	41
Weight	LBS.	2.2	2.75	2.86	3.74	4.4	6.16	9.24	9.24	14.74	23.54	35.20	50.60
CV-Value	gal/min	1.9	4.4	5.0	7.8	13.4	16.2	23.9	26.3	43.2	82.7	120.9	195.2

Dimensions in mm