

**Cryogenic-Globe and Globe/Check Valves, 725 P.S.I. (4" = 580 P.S.I.) 6" = 362 P.S.I.)**

Stainless steel body and topwork,  
 "live loaded" gland packing  
 "cleaned and degreased for oxygen service "

**Part No. 01341.X.001\* (H = 270mm)**

**Part No. 01341.X.002\* (H = 370mm)**

**Part No. 01341.X.501\* (H = 270mm) Globe/Check Valve**

**Part No. 01341.X.502\* (H = 370mm) Globe/Check Valve**

\*Butt weld connection for stainless steel pipes acc. to DIN EN ISO 1127 or ASTM A312

**Part No. 01341.X.0014 (H = 270mm)**

**Part No. 01341.X.0024 (H = 370mm)**

**Part No. 01341.X.5014 (H = 270mm) Globe/Check Valve**

**Part No. 01341.X.5024 (H = 370mm) Globe/Check Valve**

Socket weld connection for stainless steel pipes acc. to DIN EN ISO 1127 and ASTM A312

Available options - on request only:

- Welded stainless steel stubs acc. to DIN EN ISO 1127 or ASTM A312 - length FF + 150mm
- Extension H up to 900mm (36")
- Valve with control disc (tapered design)

**Applications:**

Approved for air gases, vapours and cryogenic liquefied gases incl. LNG.  
 Working temperature: -196°C / -321°F (77K) up to +120°C / +248°F (393K)

Materials	ASTM
1 Body	A 351 CF8
2 Valve seal up to DN50	PTFE / Carbon filled (25%)
2a Valve seal from DN65	PTFE
3 Disc	A 276 Grade 304
4 Bonnet gasket	PTFE
5 Headpiece	A 276 Grade 304
6 Bolts	A 194 B8
7 Elongation tube	A 213 TP 321
8 Stem	A 276 Grade 304
9 Gland packing	Graphite / PTFE
10 Gland nut	A 276 Grade 303
11 Handwheel	Aluminium alloy
12 Spring	A 276 Grade 302
13 Bush	B 103 Alloy A

Standard marking acc. to Pressure Equipment Directive 97/23/EG (PED).



Marking acc. to Directive 99/36/EG (TPED) will only be carried out by written notice on purchase order.



**GVMSS Series**

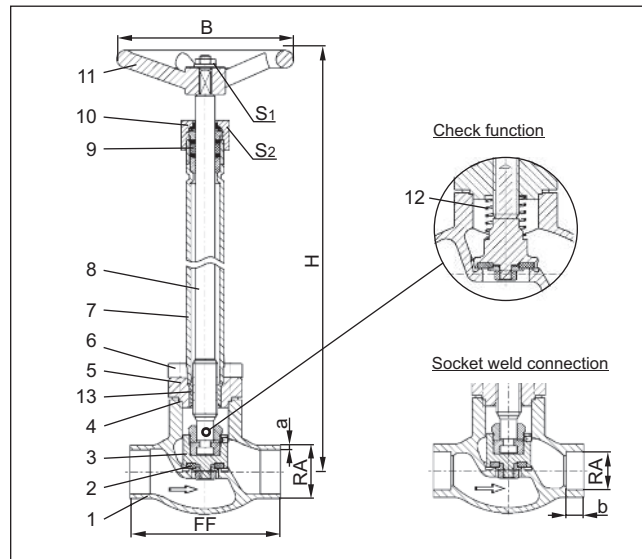

Type 01341 – Standard design	Technical data																
	Nominal size	Inches	3/8"	1/2"	1/2"	3/4"	1"	1 1/4"	1 1/2"	1 1/2"	1 1/2"	2"	2 1/2"	3"	4"	6"	
Dimensions code	.X.	1012	1517	1521	2026	2533	3238	4042	4048	5060	657x	8088	0114	0168			
Face-to-face dimension	FF	70	85	85	100	115	115	130	130	155	205	245	280	400			
Height	H			270 mm or 370 mm (10 1/2" or 14 1/2")									400	400	400	420	
Outside pipe -ø DIN EN ISO 1127	RA	12.0	17.2	21.3	26.9	33.7	38.0	42.4	48.3	60.3	76.1	88.9	114.3	168.3			
Wall thickness pipe DIN EN ISO 1127	a	1.0	1.6	2.0	2.0	2.0	2.0	2.0	2.0	2.0	2.6	3.2	6.0	7.1			
Outside pipe -ø ASTM A312	RA	13.72	17.15	21.34	26.67	33.40	-	42.16	48.26	60.33	73.03	88.90	114.3	168.3			
Wall thickness pipe ASTM A312	a	S10	S40	S10	S10	S10	-	S10	S10	S10	S40	S10	S40	S40			
Socket depth	b	6	10	10	13	13	-	13	13	16	16	16	20	20			
Handwheel-ø	B	80	100	100	100	100	125	125	125	125	200	250	315	360			
Wrench size across flats	S <sub>1</sub>	10	10	10	10	10	13	13	13	13	13	13	13	19			
Wrench size across flats	S <sub>2</sub>	30	30	30	30	30	36	36	36	36	36	36	41	41			
Weight	LBS.	3.08	3.63	3.74	4.62	5.28	7.26	10.24	10.24	15.84	27.94	37.4	53.9	118.8			
CV-Value	gal/min	1.9	4.4	5.0	7.8	13.4	16.2	23.9	26.3	43.2	82.7	120.9	195.2	401.8			

Dimensions in mm