

Cryogenic-Bellow Sealed Globe Valve, 725 P.S.I.

Stainless steel body and topwork,
“live loaded” gland packing
“ cleaned and degreased for oxygen service ”

Part No. 01252.X.002*

*Butt weld connection for stainless steel pipes acc. to DIN EN ISO 1127 or ASTM A312

Part No. 01252.X.0024

Socket weld connection for stainless steel pipes acc. to DIN EN ISO 1127 and ASTM A312

Available options - on request only:

- Welded stainless steel stubs acc. to DIN EN ISO 1127 or ASTM A312 - length FF + 150mm
- Extension H up to 900mm (36")
- Valve with control disc (tapered design)

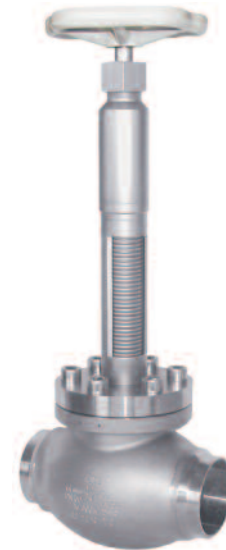

GVBLSS Series

Applications:

Approved for air gases, vapours and cryogenic liquefied gases incl. LNG.
Working temperature: -196°C / -321°F (77K) up to +120°C / +248°F (393K)

Leak rate: 10⁻⁸ mbar ltr / sec outside
10⁻⁶ mbar ltr / sec seat

Materials	ASTM
1 Body	A 351 CF8
2 Valve seal	PTFE / Carbon filled (25%)
3 Disc	A 276 Grade 304
4 Bonnet gasket	PTFE
5 Headpiece	A 276 Grade 304
6 Bellow stem	A 276 Grade 321
7 Bolts	A 194 B8
8 Bellow	A 276 Grade 321
9 Elongation tube	A 213 TP 321
10 Upper part	A 276 Grade 304
11 Bush	B 103 Alloy A
12 Stem	A 276 Grade 304
13 Gland packing	Graphite / PTFE
14 Gland nut	A 276 Grade 303
15 Handwheel	Aluminium alloy

Standard marking acc. to Pressure Equipment Directive 97/23/EG (PED).

Marking acc. to Directive 99/36/EG (TPED) will only be carried out by written notice on purchase order.

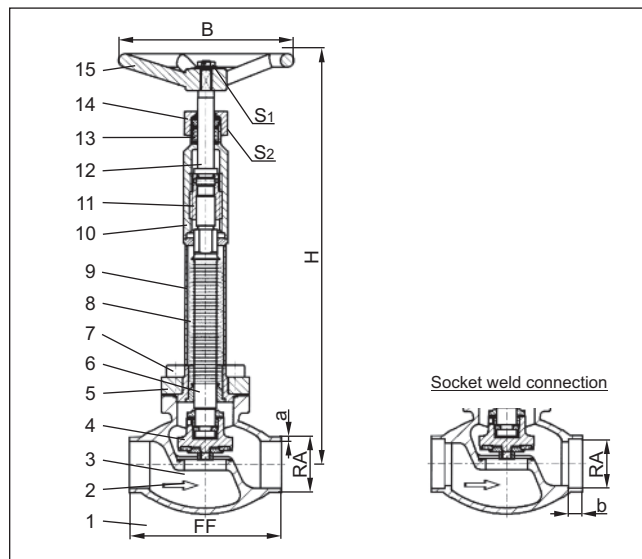

Socket weld connection

Type 01252–Standard design	Technical data										
Nominal size	Inches	3/8"	1/2"	1/2"	3/4"	1"	1 1/4"	1 1/2"	1 1/2"	2"	
Dimensions code	.X.	1012	1517	1521	2026	2533	3238	4042	4048	5060	
Face-to-face dimension	FF	70	85	85	100	115	115	130	130	155	
Height	H	380	380	380	380	380	380	380	380	380	
Outside pipe -ø DIN EN ISO 1127	RA	12.0	17.2	21.3	26.9	33.7	38.0	42.4	48.3	60.3	
Wall thickness pipe DIN EN ISO 1127	a	1.0	1.6	2.0	2.0	2.0	2.0	2.0	2.0	2.0	
Outside pipe -ø ASTM A312	RA	13.72	17.15	21.34	26.67	33.40	-	42.16	48.26	60.33	
Wall thickness pipe ASTM A312	a	S10	S40	S10	S10	S10	-	S10	S10	S10	
Socket depth	b	6	10	10	13	13	-	13	13	16	
Handwheel-ø	B	150	150	150	150	150	150	150	150	150	
Wrench size across flats	S ₁	10	10	10	10	10	13	13	13	13	
Wrench size across flats	S ₂	30	30	30	30	30	36	36	36	36	
Weight	LBS.	3.52	4.07	4.18	5.06	5.94	7.92	11.22	11.22	16.94	
CV-Value	gal/min	1.9	4.4	5.0	7.8	13.4	16.2	23.9	26.3	43.2	

Dimensions in mm