

Cryogenic-Globe Valves Angle Type, 725 P.S.I.

Stainless steel body and topwork,
“live loaded” gland packing
“ cleaned and degreased for oxygen service “

Part No. 01352.X.000*

*Butt weld connection for stainless steel pipes acc. to DIN EN ISO 1127 or ASTM A312

Part No. 01352.X.0004

Socket weld connection for stainless steel pipes acc. to DIN EN ISO 1127 and ASTM A312

Available options - on request only:

- Valve with control disc (tapered design)



GV NATSS Series

Applications:

Approved for air gases, vapours and cryogenic liquefied gases incl. LNG.
Working temperature: -196°C / -321°F (77K) up to +120°C / +248°F (393K)
Recommended working temperature: -60°C / -76°F (213K) up to +120°C / +248°F (393K)

Materials	ASTM
1 Body	A 351 CF8
2 Valve seal	PTFE / Carbon filled (25%)
3 Disc	A 276 Grade 304
4 Bonnet gasket	PTFE
5 Headpiece	A 276 Grade 304
6 Bolts	A 194 B8
8 Stem	A 276 Grade 304
9 Gland packing	Graphite / PTFE
10 Gland nut	A 276 Grade 303
11 Handwheel	Aluminium alloy
13 Bush	B 130 Alloy A

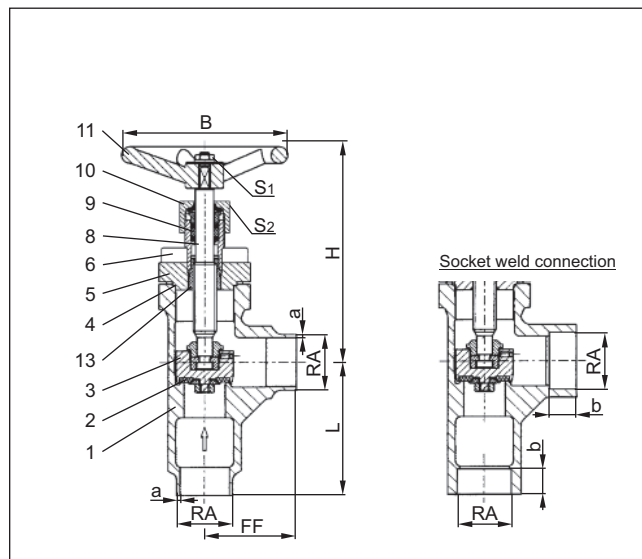

Standard marking acc. to Pressure Equipment Directive 97/23/EG (PED).



Marking acc. to Directive 99/36/EG (TPED) will only be carried out by written notice on purchase order.

Type 01352 – Standard design	Technical data							
	Nominal size	Inches	1/2"	3/4"	1"	1 1/4"	1 1/2"	2"
Dimensions code	.X.	1521	2026	2533	3242	4048	5060	
Face-to-face dimension	FF	40	50	55	60	58	85	
Height	H	140	140	140	170	175	200	
Outside pipe-ø DIN EN ISO 1127	RA	21.3	26.9	33.7	42.0	48.3	60.3	
Wall thickness pipe DIN EN ISO 1127	a	2.0	2.0	2.0	2.0	2.0	2.0	
Outside pipe-ø ASTM A312	RA	21.34	26.67	33.40	-	48.26	60.33	
Wall thickness pipe ATSM A312	a	S10	S10	S10	-	S10	S10	
Socket depth	b	10	13	13	13	13	16	
Handwheel-ø	B	100	100	100	125	125	125	
Length	L	50	65	80	80	90	90	
Wrench size across flats	S ₁	10	10	10	13	13	13	
Wrench size across flats	S ₂	30	30	30	36	36	36	
Weight	LBS.	2.2	2.86	3.74	6.82	7.26	13.2	
CV-Value	gal/min	t.b.c.	t.b.c.	t.b.c.	t.b.c.	t.b.c.	t.b.c.	

Dimensions in mm